



# ENL Series – Metric Thread Enlarger (316 Grade Stainless Steel)

- Enlargers provide an easy means to increase the size of a metric conduit thread to a larger size
- Also available in nickel plated brass

## Product Details:

- Temperature range - -40°C Min to + 110°C Max
- Material - 316 Marine Grade Stainless Steel
- Characteristics - Metric conduit thread  
- Nitrile thread sealing “O” ring included with fitting
- Applications - Ideal for seamlessly increasing the size of a conduit thread to a larger size

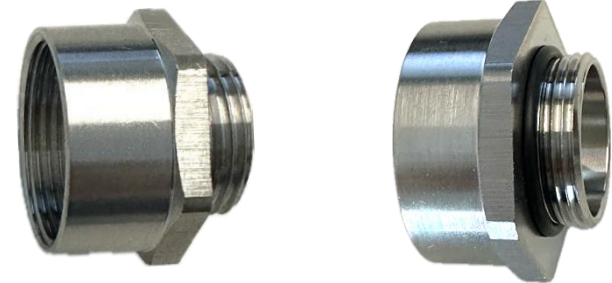
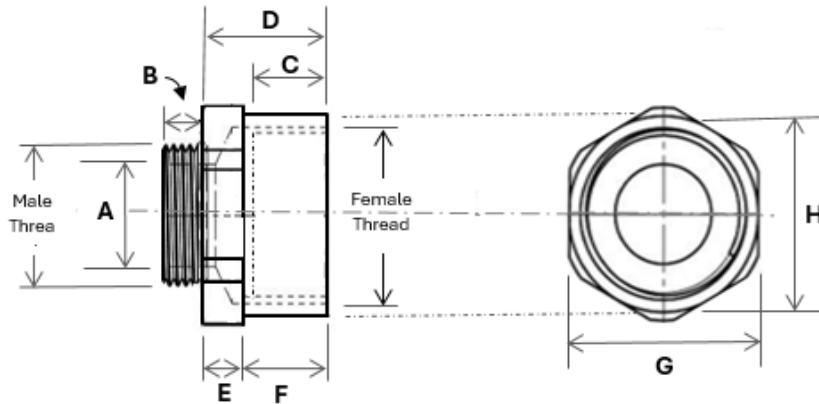

Product Catalogue No.	Male Thread Size (mm)	Female Thread Size (mm)	Internal Diameter (A) (mm)	Male Thread Length (B) (mm)	Female Thread Length (C) (mm)	Body Length (D) (mm)	Nut Width (E) (mm)	Female Body Length (F) (mm)	Hex Nut (G) (mm)	Female Body OD (H) (mm)
ENL-M16-M20-SS	M16 x 1.5	M20 x 1.5	12.0	7	9.5	11.5	4.0	7.5	23.0	22.0
ENL-M20-M25-SS	M20 x 1.5	M25 x 1.5	16.0	7	12.0	16.0	4.0	12.0	28.0	27.5
ENL-M25-M32-SS	M25 x 1.5	M32 x 1.5	21.0	7	14.0	16.5	4.5	12.0	36.0	35.0
ENL-M32-M40-SS	M32 x 1.5	M40 x 1.5	27.0	8	13.0	15.5	5.0	10.5	45.0	44.0